

# STEEL WORKBENCH

WB SERIES  
ASSEMBLY INSTRUCTIONS

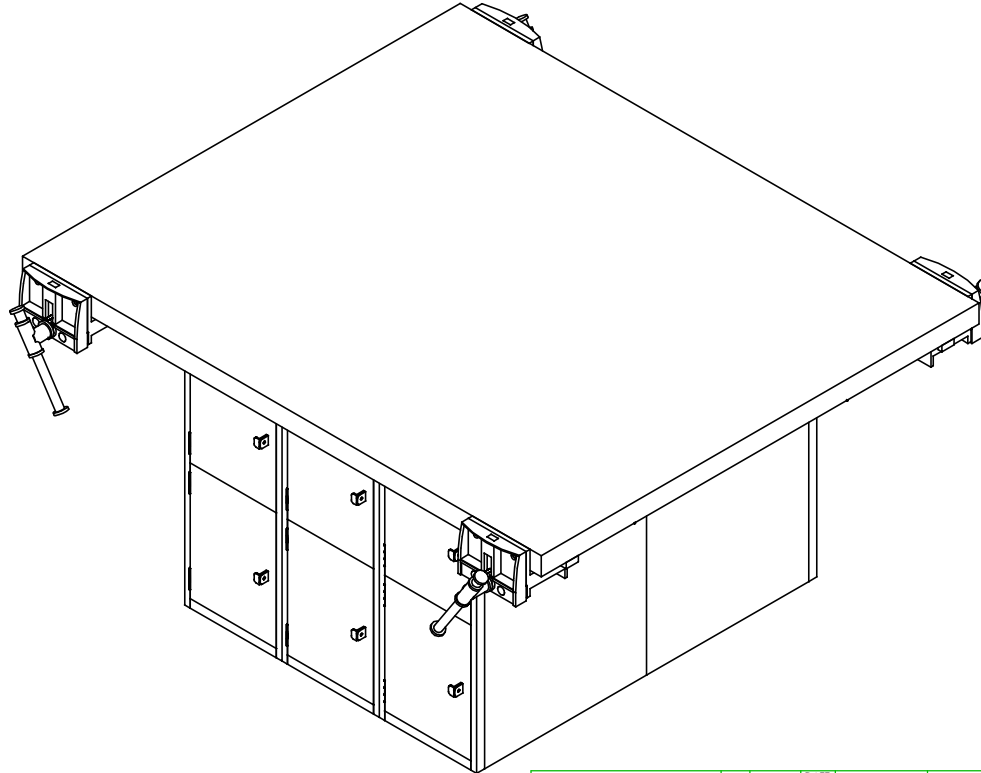

**NOTE:**

1. MODEL VIEWS MAY NOT REPRESENT EXACT MODEL PURCHASED

ALL DIMENSIONS ARE IN INCHES UNLESS NOTED OTHERWISE	DWN BY: EMK	DATE DWN: 11/28/16
CABINET SQUARENESS = ± .0625	APR BY:	DATE APR:
FRACTIONAL VALUES = ± 1/32"	APR BY:	DATE APR:
- ALL VALUES ± OVERALL -		

CONFIDENTIAL:  
ALL DESIGN RIGHTS RESERVED  
THE INFORMATION, DATA, DESIGN, AND DRAWINGS EMBODIED IN THIS DOCUMENT AND ALL REPRODUCTIONS THEREOF ARE THE EXCLUSIVE PROPERTY OF DIVERSIFIED WOODCRAFTS, INC.

THESE DOCUMENTS ARE SUPPLIED WITH THE UNDERSTANDING THAT THEY WILL NOT BE DISCLOSED TO THIRD PARTIES WITHOUT WRITTEN CONSENT OF DIVERSIFIED WOODCRAFTS, INC. ANY REPRODUCTION IN PART OR WHOLE WITHOUT WRITTEN CONSENT IS SUBJECT TO LEGAL ACTION.



300 South Krueger Street  
Suring, WI 54174  
diversifiedwoodcrafts.com

TITLE:  
STEEL WORKBENCH  
ASSEMBLY INSTRUCTIONS

REV.	DESCRIPTION	DATE	NAME	ECN NO.
A	CREATED DRAWING	11/28/16	EMK	-
REVISION LEVEL				

DRAWING NUMBER: <b>WB SERIES</b>	SCALE: NTS	SHEET: 1 OF 17	REVISION: REV A
-------------------------------------	---------------	-------------------	--------------------

## TOOLS REQUIRED

1/2" WRENCH
1/2" SOCKET AND TORQUE WRENCH - OPTIONAL
DRILL
**PHILIPS SCREW DRIVER**

## ASSEMBLY COMPONENTS

ITEMS INCLUDED	PART #	PART DESCRIPTION	QTY
TOP	16-0036 OR 16-0052	TOP,MPL, (2.25X28X64) OR TOP,MPL,(2.25X54X64)	1
STEEL BASE	VARIES	METAL BASE (STYLE VARIES)	VARIES
FLEXIBLE ANGLES - GREY	20-0001 OR 20-0002	FLEXIBLE ANGLES - 17" - AI18-GREY OR FLEXIBLE ANGLES - 42" - AI42-GREY	2
FLEXIBLE ANGLES - BLACK	236104 OR 236105	FLEXIBLE ANGLES - 17" - AI18-BLACK OR FLEXIBLE ANGLES - 42" - AI42-BLACK	2
HARDWARE	20-0050	FLEXIBLE - 4824363 - HARDWARE	1
GUSSET	253728	GUSSET,STEEL,12GAX8X8,ZINC PLATED	4
SCREWS - GUSSET	100037	SCREW,#10X5/8 QUAD PNHD LUB	12
VICES - OPTIONAL	234708	WISE - SHAIN CUSTOM VISE WITH LOGO	VARIES
**HANDLE HARDWARE BAG**	N/A	HARDWARE BAG (HANDLE, CAM, CAM PLATE, SCREWS, CLIP, LOCKING BARS INCLUDED)	1

**NOTE:**

1. TOPS ARE 2 1/4" MAPLE.
2. COMPONENTS VARY WITH STYLE OF STEEL WORKBENCH PURCHASED.
3. **\*\*XX\*\*** INDICATES ITEMS USED ONLY FOR 2 DOOR METAL BASE UNITS.

REV.	DESCRIPTION	DATE	NAME	ECN NO.
A	CREATED DRAWING	11/28/16	EMK	-
REVISION LEVEL				

ALL DIMENSIONS ARE IN INCHES UNLESS NOTED OTHERWISE	DWN BY: EMK	DATE DWN: 11/28/16
CABINET SQUARENESS = ± .0625	APR BY:	DATE APR:
FRACTIONAL VALUES = ± 1/32"	APR BY:	DATE APR:
- ALL VALUES ± OVERALL -		

CONFIDENTIAL:  
ALL DESIGN RIGHTS RESERVED  
THE INFORMATION, DATA, DESIGN, AND DRAWINGS EMBODIED IN THIS DOCUMENT AND ALL REPRODUCTIONS THEREOF ARE THE EXCLUSIVE PROPERTY OF DIVERSIFIED WOODCRAFTS, INC.

THESE DOCUMENTS ARE SUPPLIED WITH THE UNDERSTANDING THAT THEY WILL NOT BE DISCLOSED TO THIRD PARTIES WITHOUT WRITTEN CONSENT OF DIVERSIFIED WOODCRAFTS, INC. ANY REPRODUCTION IN PART OR WHOLE WITHOUT WRITTEN CONSENT IS SUBJECT TO LEGAL ACTION.



300 South Krueger Street  
Suring, WI 54174  
diversifiedwoodcrafts.com

TITLE:  
STEEL WORKBENCH  
TOOLS AND ASSEMBLY COMPONENTS

DRAWING NUMBER: <b>WB SERIES</b>	SCALE: NTS	SHEET: 2 OF 17	REVISION: REV A
-------------------------------------	---------------	-------------------	--------------------

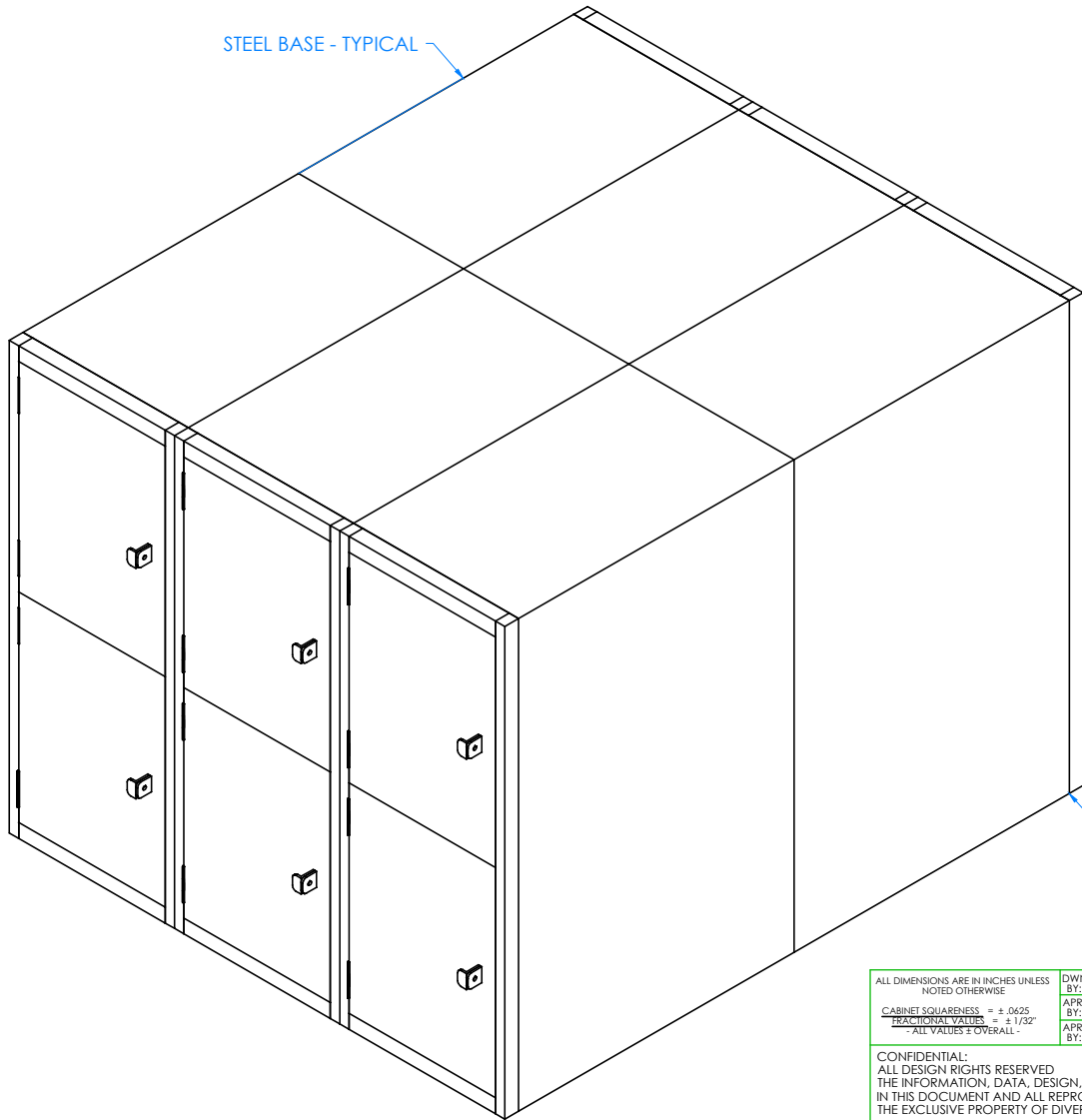

STEP 1:

- POSITION STEEL BASE IN DESIRED LOCATION.
- IF YOU HAVE A FOUR STATION WORKBENCH, PLACE STEEL BASES BACK TO BACK.
- LEVEL CABINETS.
- ANCHOR CABINETS TO EACH OTHER.

**\*\*NOTE\*\***  
 CABINETS MUST BE LEVELED OR  
 DOORS AND DRAWERS MAY NOT  
 OPEN OR CLOSE CORRECTLY

NOTE:

1.

ALL DIMENSIONS ARE IN INCHES UNLESS NOTED OTHERWISE	DWN BY: EMK	DATE DWN: 11/28/16
CABINET SQUARENESS = ± .0625	APR BY:	DATE APR:
FRACTIONAL VALUES = ± 1/32"	APR BY:	DATE APR:
- ALL VALUES ± OVERALL -		

CONFIDENTIAL:  
 ALL DESIGN RIGHTS RESERVED  
 THE INFORMATION, DATA, DESIGN, AND DRAWINGS EMBODIED IN THIS DOCUMENT AND ALL REPRODUCTIONS THEREOF ARE THE EXCLUSIVE PROPERTY OF DIVERSIFIED WOODCRAFTS, INC.

THESE DOCUMENTS ARE SUPPLIED WITH THE UNDERSTANDING THAT THEY WILL NOT BE DISCLOSED TO THIRD PARTIES WITHOUT WRITTEN CONSENT OF DIVERSIFIED WOODCRAFTS, INC. ANY REPRODUCTION IN PART OR WHOLE WITHOUT WRITTEN CONSENT IS SUBJECT TO LEGAL ACTION.



300 South Krueger Street  
 Suring, WI 54174  
 diversifiedwoodcrafts.com

TITLE:  
 STEEL WORKBENCH  
 ASSEMBLY INSTRUCTIONS

REV.	DESCRIPTION	DATE	NAME	ECN NO.
A	CREATED DRAWING	11/28/16	EMK	-
REVISION LEVEL				

DRAWING NUMBER: <b>WB SERIES</b>	SCALE: NTS	SHEET: 3 OF 17	REVISION: REV A
-------------------------------------	---------------	-------------------	--------------------

FLEXIBLE ANGLE - TYPICAL  
ATTACH TO SIDE OF STEEL BASE  
(REPEAT ON OTHER SIDE)

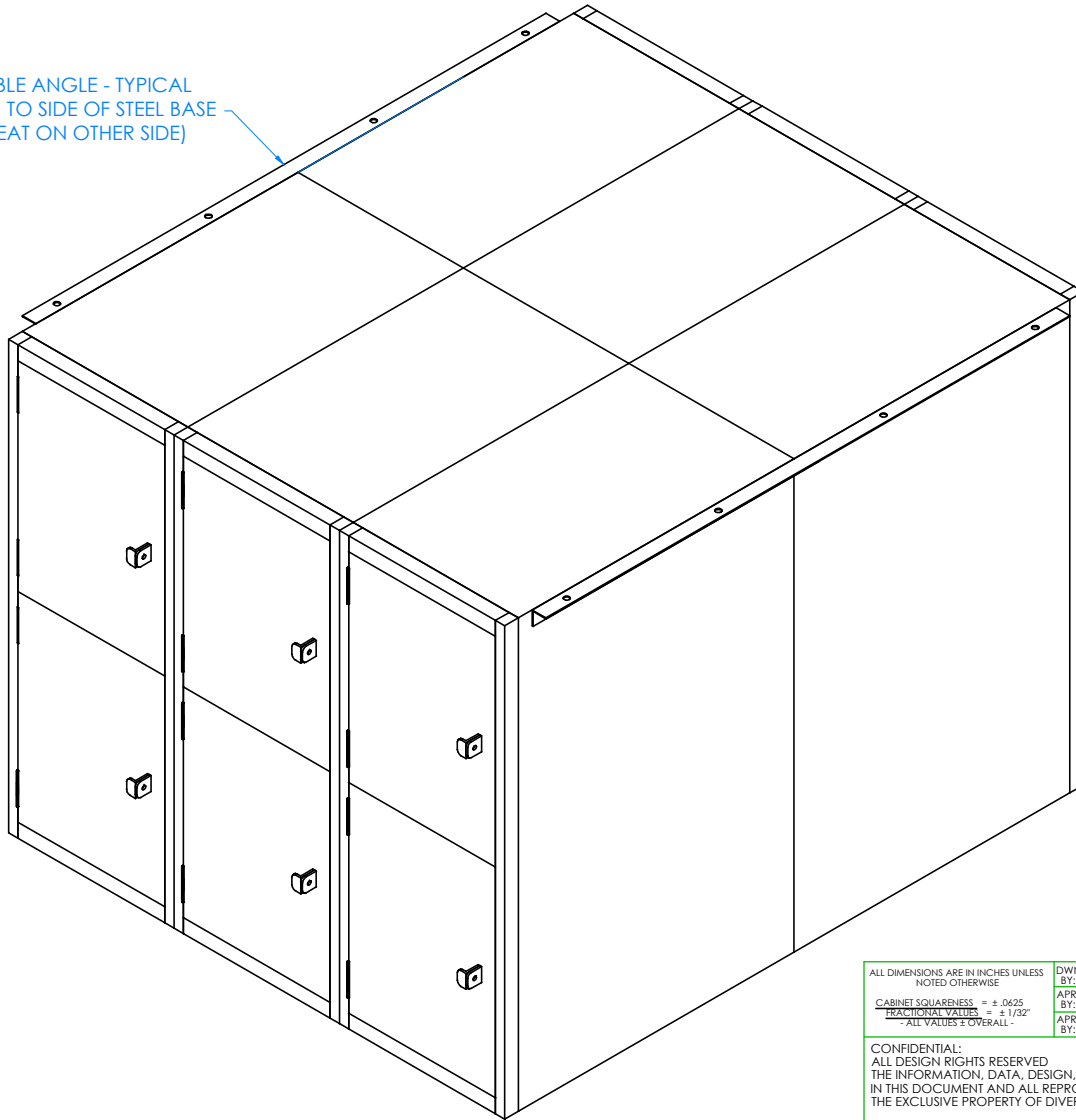

STEP 2:

- PLACE FLEXIBLE ANGLE ON SIDE OF STEEL BASE.
- MAKE SURE IT IS CENTERED AND TOP EDGE OF FLEXIBLE ANGLE IS FLUSH WITH TOP EDGE OF CABINETS.
- ATTACH ANGLES TO SIDES OF BASE WITH HARDWARE PROVIDED.
- BOLTS GO HORIZONTALLY THROUGH ANGLE INTO BASE.
- NUTS AND WASHERS ARE TIGHTENED TO BOLT FROM INSIDE OF BASE.
- TIGHTEN NUT USING 1/2" WRENCH OR 1/2" SOCKET AND TORQUE WRENCH, TO A MINIMUM OF 12FT LBS BUT NOT TO EXCEED 17FT LBS.
- REPEAT ON OTHER SIDE.

NOTE:

1.

ALL DIMENSIONS ARE IN INCHES UNLESS NOTED OTHERWISE	DWN BY: EMK	DATE DWN: 11/28/16
CABINET SQUARENESS = ± .0625	APR BY:	DATE APR:
FRACTIONAL VALUES = ± 1/32"	APR BY:	DATE APR:
- ALL VALUES ± OVERALL -		

CONFIDENTIAL:  
ALL DESIGN RIGHTS RESERVED  
THE INFORMATION, DATA, DESIGN, AND DRAWINGS EMBODIED IN THIS DOCUMENT AND ALL REPRODUCTIONS THEREOF ARE THE EXCLUSIVE PROPERTY OF DIVERSIFIED WOODCRAFTS, INC.

THESE DOCUMENTS ARE SUPPLIED WITH THE UNDERSTANDING THAT THEY WILL NOT BE DISCLOSED TO THIRD PARTIES WITHOUT WRITTEN CONSENT OF DIVERSIFIED WOODCRAFTS, INC. ANY REPRODUCTION IN PART OR WHOLE WITHOUT WRITTEN CONSENT IS SUBJECT TO LEGAL ACTION.



300 South Krueger Street  
Suring, WI 54174  
diversifiedwoodcrafts.com

TITLE:  
STEEL WORKBENCH  
ASSEMBLY INSTRUCTIONS

REV.	DESCRIPTION	DATE	NAME	ECN NO.
A	CREATED DRAWING	11/28/16	EMK	-
REVISION LEVEL				

DRAWING NUMBER: <b>WB SERIES</b>	SCALE: NTS	SHEET: 4 OF 17	REVISION: REV A
-------------------------------------	---------------	-------------------	--------------------

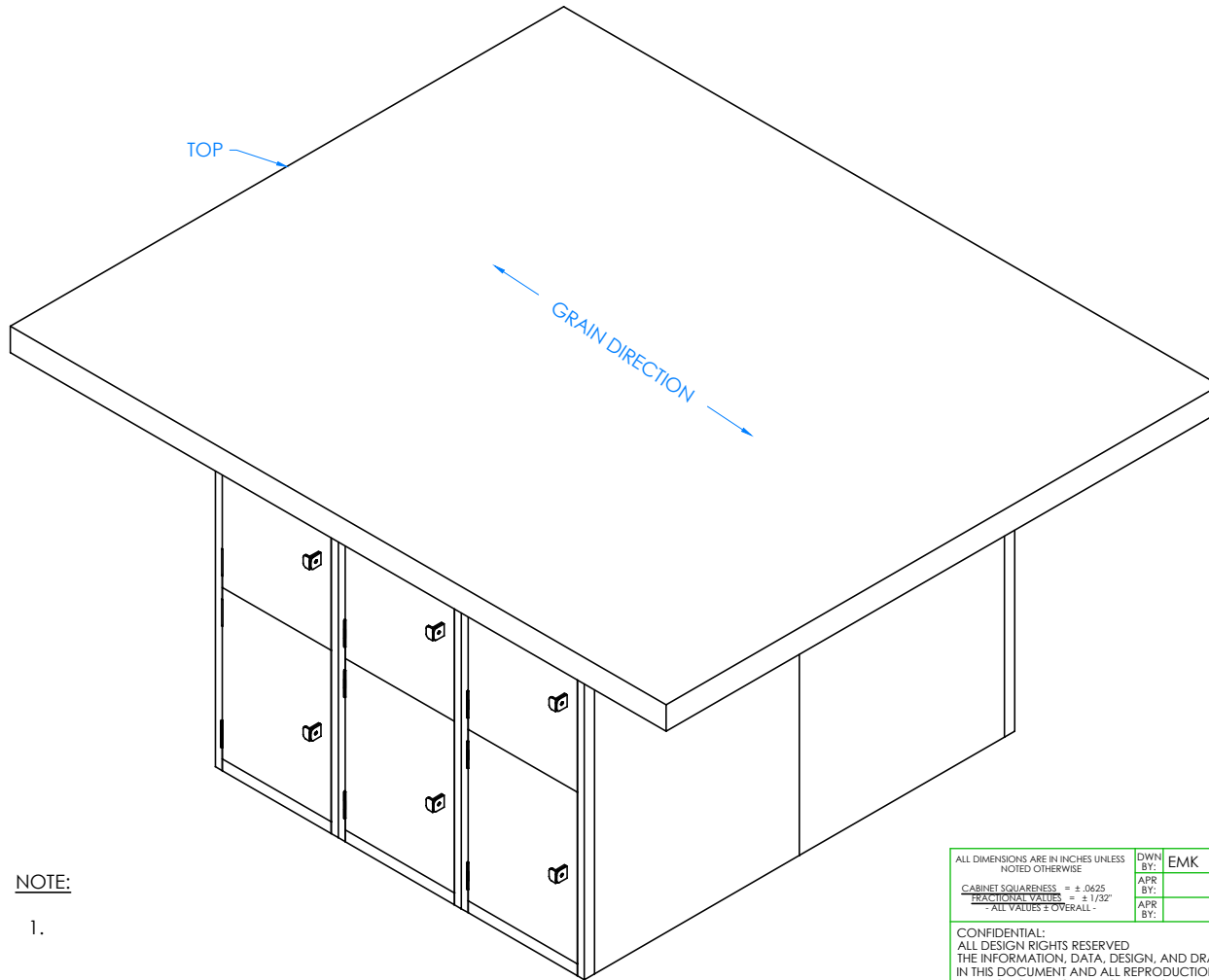

STEP 3:

- PLACE CARDBOARD ON TOP OF STEEL BASE IN CORNERS AND CENTER BEFORE INSTALLING TOP (NOT SHOWN).
- THIS ALLOWS MAPLE TOP TO BREATHE.
- LAY TOP ON STEEL BASE WITH PROPER OVERHANG (CENTERED ON WORKBENCH) AND GRAIN RUNNING PROPER DIRECTION.
- LAG SCREWS GO VERTICALLY THROUGH ANGLE SUPPORT UP INTO TOP.
- PRE-DRILL HOLES IN TOP FOR LAG SCREWS.

NOTE:

1.

ALL DIMENSIONS ARE IN INCHES UNLESS NOTED OTHERWISE	DWN BY: EMK	DATE DWN: 11/28/16
CABINET SQUARENESS = ± .0625	APR BY:	DATE APR:
FRACTIONAL VALUES = ± 1/32"	APR BY:	DATE APR:
- ALL VALUES ± OVERALL -		

CONFIDENTIAL:  
ALL DESIGN RIGHTS RESERVED  
THE INFORMATION, DATA, DESIGN, AND DRAWINGS EMBODIED IN THIS DOCUMENT AND ALL REPRODUCTIONS THEREOF ARE THE EXCLUSIVE PROPERTY OF DIVERSIFIED WOODCRAFTS, INC.

THESE DOCUMENTS ARE SUPPLIED WITH THE UNDERSTANDING THAT THEY WILL NOT BE DISCLOSED TO THIRD PARTIES WITHOUT WRITTEN CONSENT OF DIVERSIFIED WOODCRAFTS, INC. ANY REPRODUCTION IN PART OR WHOLE WITHOUT WRITTEN CONSENT IS SUBJECT TO LEGAL ACTION.



300 South Krueger Street  
Suring, WI 54174  
diversifiedwoodcrafts.com

TITLE:  
STEEL WORKBENCH  
ASSEMBLY INSTRUCTIONS

REV.	DESCRIPTION	DATE	NAME	ECN NO.
A	CREATED DRAWING	11/28/16	EMK	-

REVISION LEVEL

DRAWING NUMBER: <b>WB SERIES</b>	SCALE: NTS	SHEET: 5 OF 17	REVISION: REV A
-------------------------------------	---------------	-------------------	--------------------

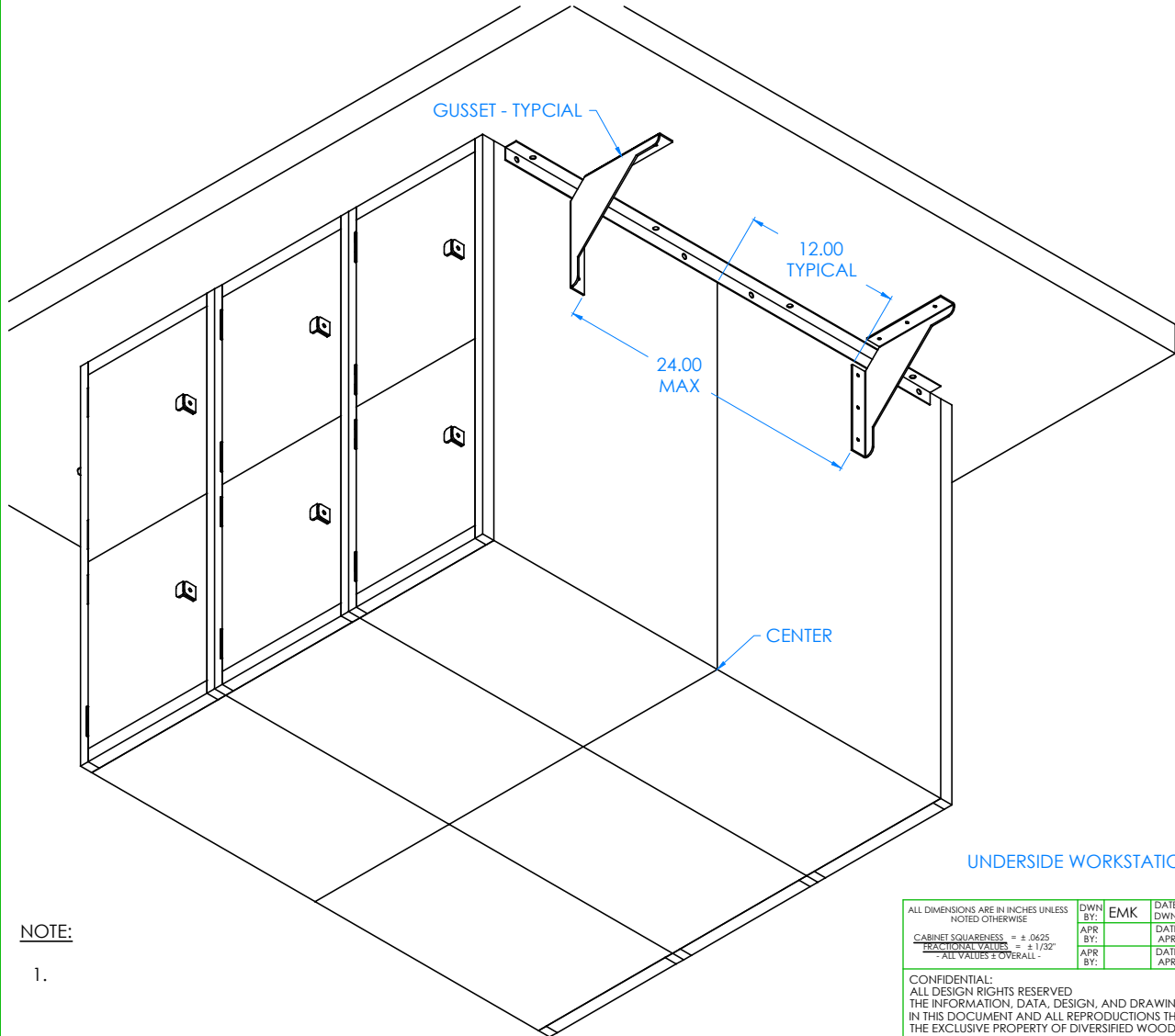

STEP 4:

- ATTACH STEEL GUSSETS TO TOP WITH CORRECT DISTANCE IN BETWEEN WITH HARDWARE PROVIDED.
- FROM CENTER OF BASE CABINETS, PLACE GUSSETS 12" TOWARDS FRONT OF WORKBENCH FOR A TOTAL OF 24" IN BETWEEN.
- THE EDGE OF THE GUSSET WITH THROUGH HOLES SHOULD BE FACING EACH OTHER.
- PRE-DRILL HOLES IN TOP TO PREVENT CRACKING.
- STEEL GUSSETS MUST BE TIGHT AGAINST CABINET SIDES.

UNDERSIDE WORKSTATION SHOWN

NOTE:  
1.

ALL DIMENSIONS ARE IN INCHES UNLESS NOTED OTHERWISE	DWN BY: EMK	DATE DWN: 11/28/16
CABINET SQUARENESS = ± .0625	APR BY:	DATE APR:
FRACTIONAL VALUES = ± 1/32"	APR BY:	DATE APR:
- ALL VALUES ± OVERALL -		

CONFIDENTIAL:  
ALL DESIGN RIGHTS RESERVED  
THE INFORMATION, DATA, DESIGN, AND DRAWINGS EMBODIED IN THIS DOCUMENT AND ALL REPRODUCTIONS THEREOF ARE THE EXCLUSIVE PROPERTY OF DIVERSIFIED WOODCRAFTS, INC.

THESE DOCUMENTS ARE SUPPLIED WITH THE UNDERSTANDING THAT THEY WILL NOT BE DISCLOSED TO THIRD PARTIES WITHOUT WRITTEN CONSENT OF DIVERSIFIED WOODCRAFTS, INC. ANY REPRODUCTION IN PART OR WHOLE WITHOUT WRITTEN CONSENT IS SUBJECT TO LEGAL ACTION.



300 South Krueger Street  
Suring, WI 54174  
diversifiedwoodcrafts.com

TITLE:  
STEEL WORKBENCH  
ASSEMBLY INSTRUCTIONS

A	CREATED DRAWING	11/28/16	EMK	-
REV.	DESCRIPTION	DATE	NAME	ECN NO.

REVISION LEVEL

DRAWING NUMBER: <b>WB SERIES</b>	SCALE: NTS	SHEET: 6 OF 17	REVISION: REV A
-------------------------------------	---------------	-------------------	--------------------

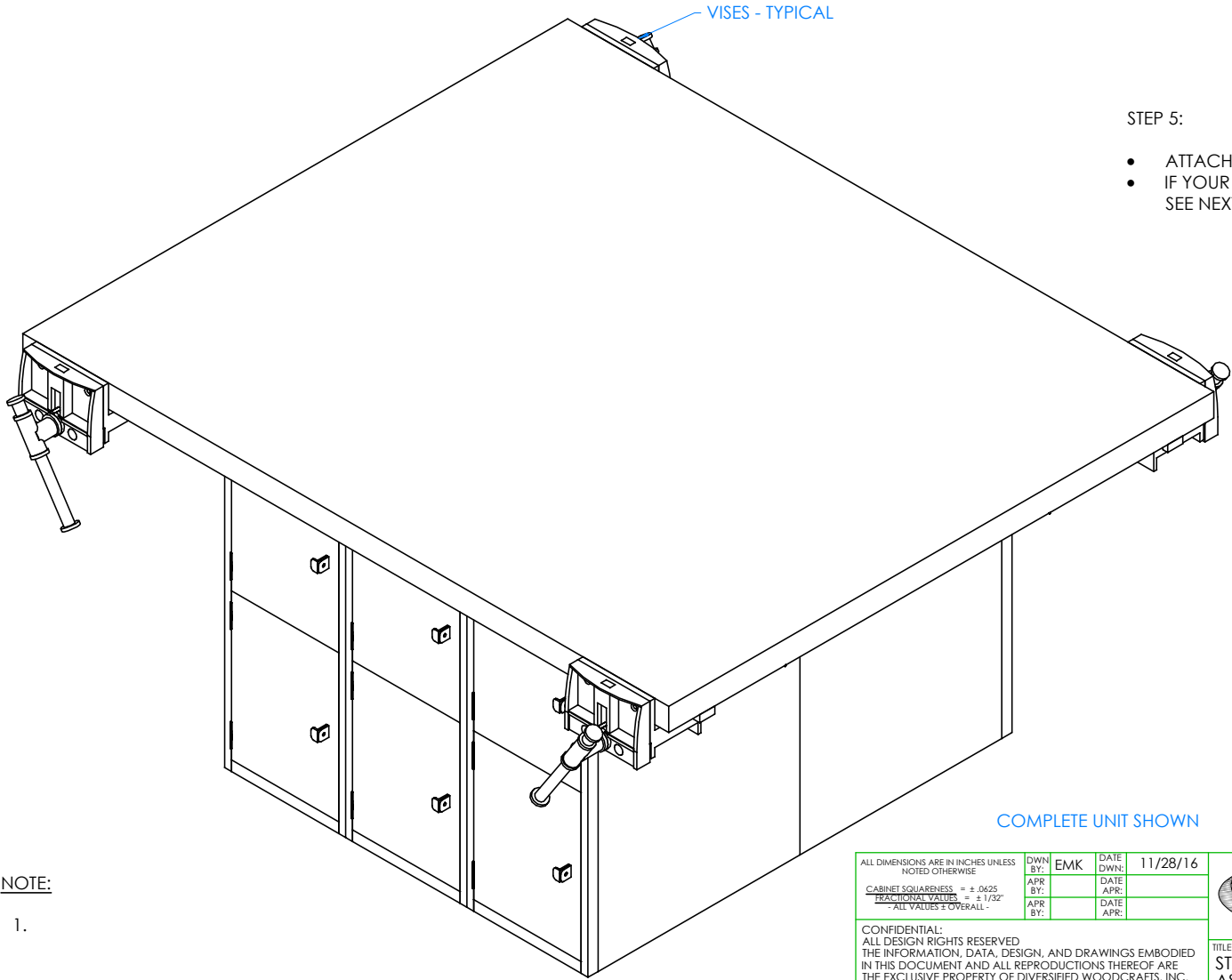

STEP 5:

- ATTACH VISES IF INCLUDED.
- IF YOUR UNIT IS A TWO DOOR LOCKER BASE WORKSTATION, SEE NEXT STEPS ON HOW TO ASSEMBLY HANDLE!

COMPLETE UNIT SHOWN

NOTE:  
1.

ALL DIMENSIONS ARE IN INCHES UNLESS NOTED OTHERWISE	DWN BY: EMK	DATE DWN: 11/28/16
CABINET SQUARENESS = ± .0625	APR BY:	DATE APR:
FRACTIONAL VALUES = ± 1/32"	APR BY:	DATE APR:
- ALL VALUES ± OVERALL -		

CONFIDENTIAL:  
ALL DESIGN RIGHTS RESERVED  
THE INFORMATION, DATA, DESIGN, AND DRAWINGS EMBODIED IN THIS DOCUMENT AND ALL REPRODUCTIONS THEREOF ARE THE EXCLUSIVE PROPERTY OF DIVERSIFIED WOODCRAFTS, INC.

THESE DOCUMENTS ARE SUPPLIED WITH THE UNDERSTANDING THAT THEY WILL NOT BE DISCLOSED TO THIRD PARTIES WITHOUT WRITTEN CONSENT OF DIVERSIFIED WOODCRAFTS, INC. ANY REPRODUCTION IN PART OR WHOLE WITHOUT WRITTEN CONSENT IS SUBJECT TO LEGAL ACTION.



300 South Krueger Street  
Suring, WI 54174  
diversifiedwoodcrafts.com

TITLE:  
STEEL WORKBENCH  
ASSEMBLY INSTRUCTIONS

REV.	DESCRIPTION	DATE	NAME	ECN NO.
A	CREATED DRAWING	11/28/16	EMK	-
REVISION LEVEL				

DRAWING NUMBER: <b>WB SERIES</b>	SCALE: NTS	SHEET: 7 OF 17	REVISION: REV A
-------------------------------------	---------------	-------------------	--------------------

STEP 6:

- POSITION AND SECURE HANDLE TO DOOR.
- ATTACH WITH HARDWARE PROVIDED.

DOOR PANEL

SLOTTED MACHINE SCREW - TYPICAL

HANDLE

BACKSIDE OF DOOR SHOWN

**NOTE:**

1. THESE ARE FOR THE TWO DOOR LOCKER BASE UNITS:

1.1. EX.: WB2, WB2BL, WBD2, AND WBD2BL.

ALL DIMENSIONS ARE IN INCHES UNLESS NOTED OTHERWISE		DWN BY: EMK	DATE DWN: 11/28/16
CABINET SQUARENESS = ± .0625	APR BY:	DATE APR:	
FRACTIONAL VALUES = ± 1/32"	APR BY:	DATE APR:	
- ALL VALUES ± OVERALL -			

CONFIDENTIAL:  
ALL DESIGN RIGHTS RESERVED  
THE INFORMATION, DATA, DESIGN, AND DRAWINGS EMBODIED IN THIS DOCUMENT AND ALL REPRODUCTIONS THEREOF ARE THE EXCLUSIVE PROPERTY OF DIVERSIFIED WOODCRAFTS, INC.

THESE DOCUMENTS ARE SUPPLIED WITH THE UNDERSTANDING THAT THEY WILL NOT BE DISCLOSED TO THIRD PARTIES WITHOUT WRITTEN CONSENT OF DIVERSIFIED WOODCRAFTS, INC. ANY REPRODUCTION IN PART OR WHOLE WITHOUT WRITTEN CONSENT IS SUBJECT TO LEGAL ACTION.



300 South Krueger Street  
Suring, WI 54174  
diversifiedwoodcrafts.com

TITLE:  
STEEL WORKBENCH  
ASSEMBLY INSTRUCTIONS

REV.	DESCRIPTION	DATE	EMK NAME	ECN No.
A	CREATED DRAWING	11/28/16	EMK	N/A
REVISION LEVEL				

DRAWING NUMBER:	SCALE:	SHEET:	REVISION:
WB SERIES	NTS	8 OF 17	REV A



STEP 7:

- POSITION CAM ON THE HANDLE SHAFT.

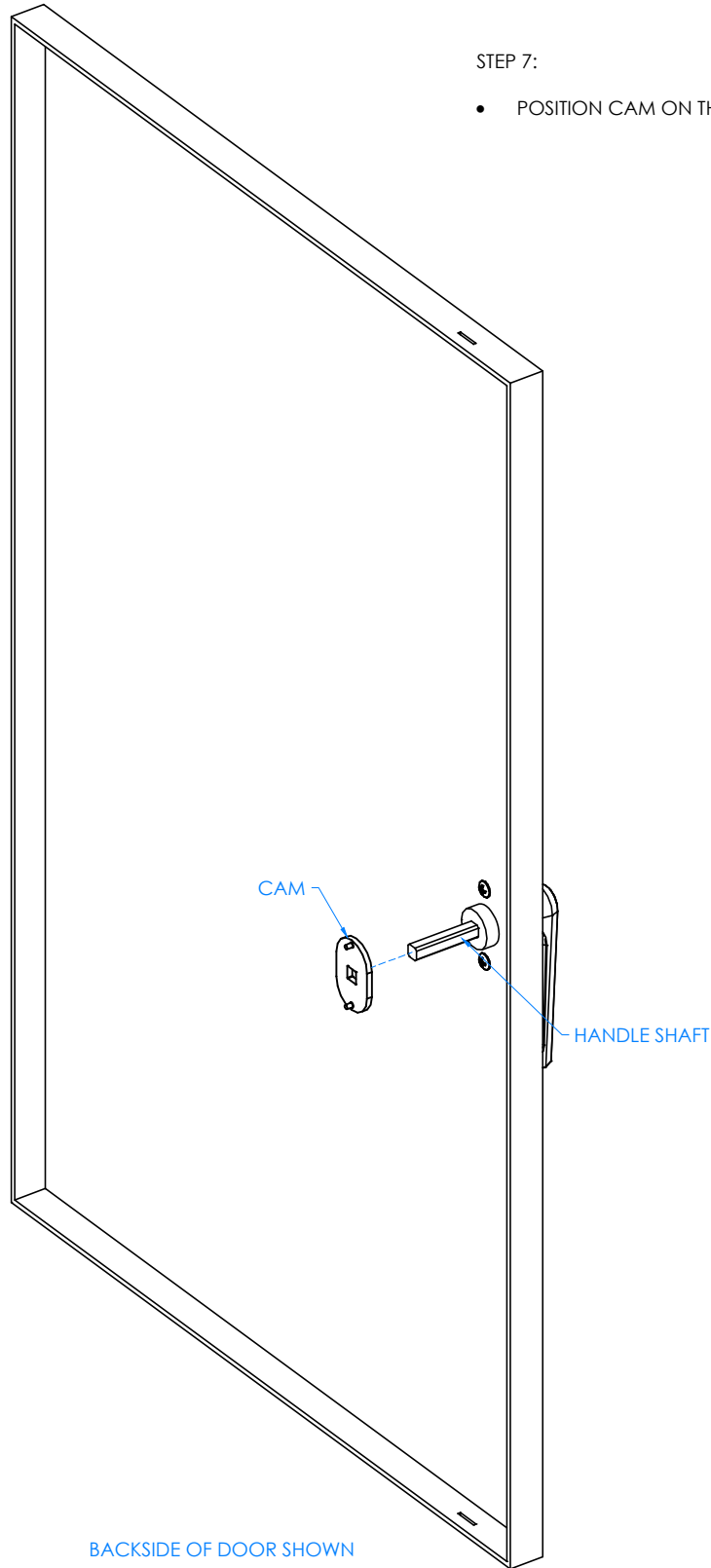

BACKSIDE OF DOOR SHOWN

**NOTE:**

1. THESE ARE FOR THE TWO DOOR LOCKER BASE UNITS:

1.1. EX.: WB2, WB2BL, WBD2, AND WBD2BL.

ALL DIMENSIONS ARE IN INCHES UNLESS NOTED OTHERWISE	DWN BY: EMK	DATE DWN: 11/28/16
CABINET SQUARENESS = ± .0625	APR BY:	DATE APR:
FRACTIONAL VALUES = ± 1/32"	APR BY:	DATE APR:
- ALL VALUES ± OVERALL -		

CONFIDENTIAL:  
ALL DESIGN RIGHTS RESERVED  
THE INFORMATION, DATA, DESIGN, AND DRAWINGS EMBODIED IN THIS DOCUMENT AND ALL REPRODUCTIONS THEREOF ARE THE EXCLUSIVE PROPERTY OF DIVERSIFIED WOODCRAFTS, INC.

THESE DOCUMENTS ARE SUPPLIED WITH THE UNDERSTANDING THAT THEY WILL NOT BE DISCLOSED TO THIRD PARTIES WITHOUT WRITTEN CONSENT OF DIVERSIFIED WOODCRAFTS, INC. ANY REPRODUCTION IN PART OR WHOLE WITHOUT WRITTEN CONSENT IS SUBJECT TO LEGAL ACTION.



300 South Krueger Street  
Suring, WI 54174  
diversifiedwoodcrafts.com

TITLE:  
STEEL WORKBENCH  
ASSEMBLY INSTRUCTIONS

REV.	DESCRIPTION	DATE	NAME	ECN No.
A	CREATED DRAWING	11/28/16	EMK	N/A
REVISION LEVEL				

DRAWING NUMBER:	SCALE:	SHEET:	REVISION:
WB SERIES	NTS	9 OF 17	REV A

STEP 8:

- PLACE THE TWO LOCKING RODS THROUGH THE SLOTS LOCATED ON TOP AND BOTTOM EDGES OF DOOR.
- SET LOCKING RODS ON CAM PINS.

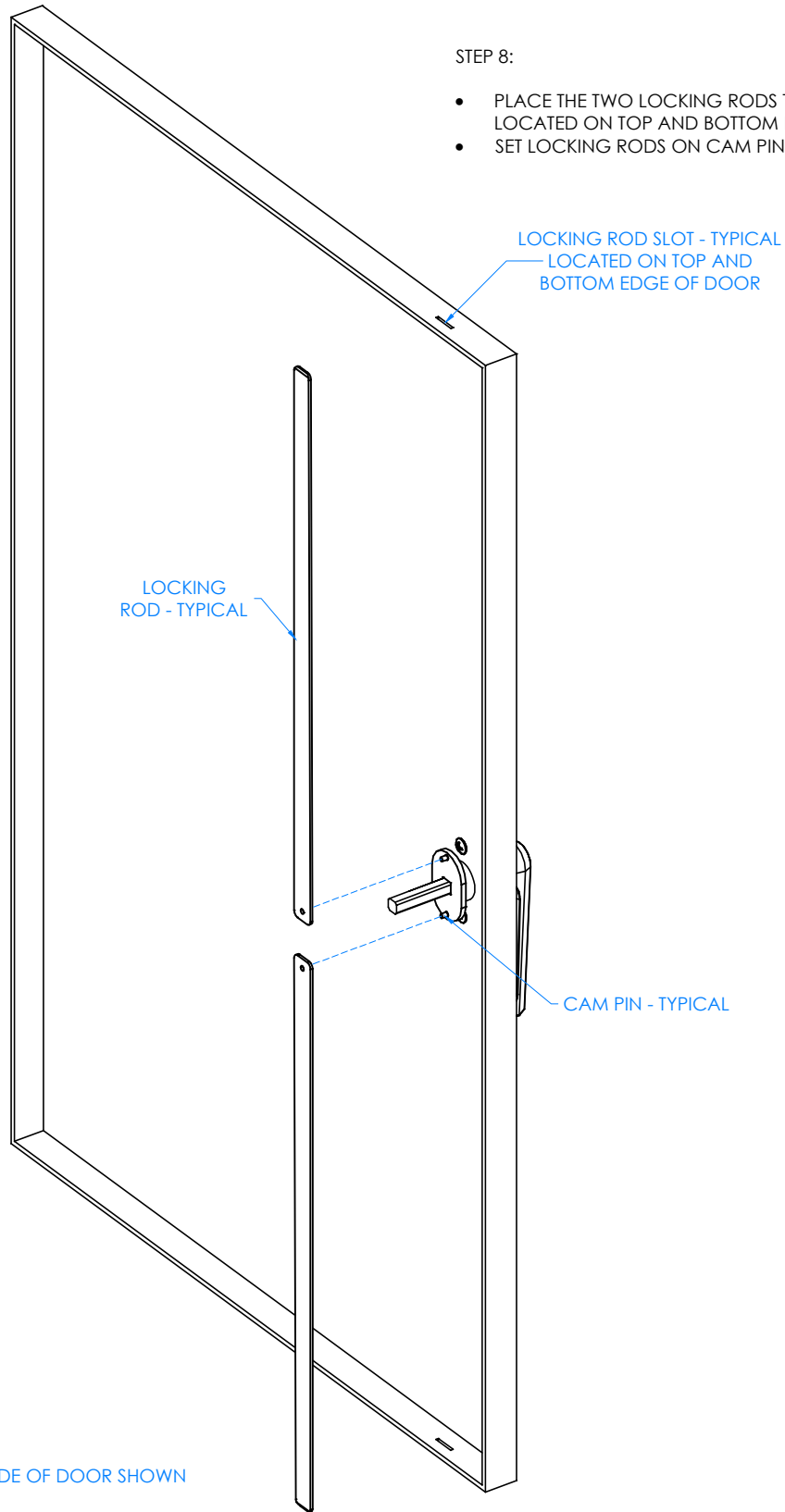

BACKSIDE OF DOOR SHOWN

**NOTE:**

1. THESE ARE FOR THE TWO DOOR LOCKER BASE UNITS:  
1.1. EX.: WB2, WB2BL, WBD2, AND WBD2BL.

ALL DIMENSIONS ARE IN INCHES UNLESS NOTED OTHERWISE		DWN BY: EMK	DATE DWN: 11/28/16
CABINET SQUARENESS ± 0.025	APR BY:	DATE APR:	
FRACTIONAL VALUES ± 1/32"	APR BY:	DATE APR:	
- ALL VALUES ± OVERALL -			

CONFIDENTIAL:  
ALL DESIGN RIGHTS RESERVED  
THE INFORMATION, DATA, DESIGN, AND DRAWINGS EMBODIED IN THIS DOCUMENT AND ALL REPRODUCTIONS THEREOF ARE THE EXCLUSIVE PROPERTY OF DIVERSIFIED WOODCRAFTS, INC.

THESE DOCUMENTS ARE SUPPLIED WITH THE UNDERSTANDING THAT THEY WILL NOT BE DISCLOSED TO THIRD PARTIES WITHOUT WRITTEN CONSENT OF DIVERSIFIED WOODCRAFTS, INC. ANY REPRODUCTION IN PART OR WHOLE WITHOUT WRITTEN CONSENT IS SUBJECT TO LEGAL ACTION.



300 South Krueger Street  
Suring, WI 54174  
diversifiedwoodcrafts.com

TITLE:  
STEEL WORKBENCH  
ASSEMBLY INSTRUCTIONS

REV.	DESCRIPTION	DATE	EMK NAME	N/A ECN No.
A	CREATED DRAWING	11/28/16	EMK	N/A
REVISION LEVEL				

DRAWING NUMBER:	SCALE:	SHEET:	REVISION:
WB SERIES	NTS	10 OF 17	REV A

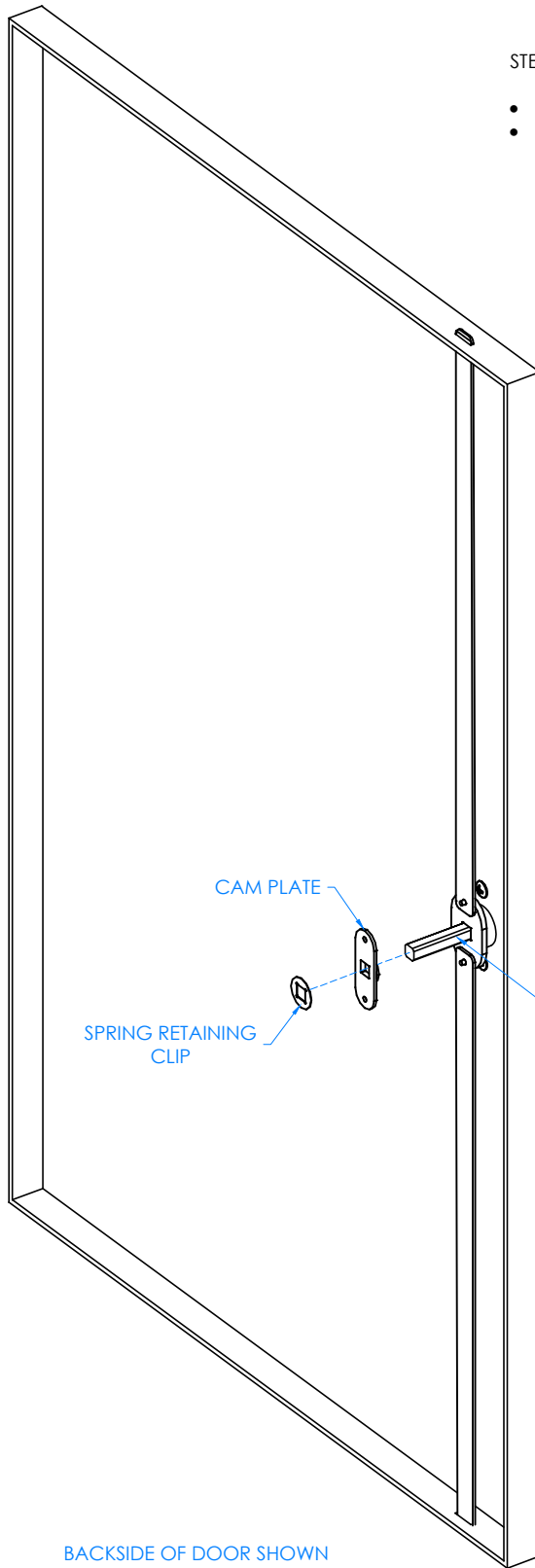

STEP 9:

- INSERT CAM PLATE ON HANDLE SHAFT AND CAM PINS.
- SECURE WITH SPRING RETAINER CLIP.

CAM PLATE

SPRING RETAINING CLIP

HANDLE SHAFT

BACKSIDE OF DOOR SHOWN

**NOTE:**

1. THESE ARE FOR THE TWO DOOR LOCKER BASE UNITS:

1.1. EX.: WB2, WB2BL, WBD2, AND WBD2BL.

ALL DIMENSIONS ARE IN INCHES UNLESS NOTED OTHERWISE		DWN BY:	EMK	DATE DWN:	11/28/16
CABINET SQUARENESS = ± .0625		APR BY:		DATE APR:	
FRACTIONAL VALUES = ± 1/32"		APR BY:		DATE APR:	
- ALL VALUES ± OVERALL -					

CONFIDENTIAL:  
ALL DESIGN RIGHTS RESERVED  
THE INFORMATION, DATA, DESIGN, AND DRAWINGS EMBODIED IN THIS DOCUMENT AND ALL REPRODUCTIONS THEREOF ARE THE EXCLUSIVE PROPERTY OF DIVERSIFIED WOODCRAFTS, INC.

THESE DOCUMENTS ARE SUPPLIED WITH THE UNDERSTANDING THAT THEY WILL NOT BE DISCLOSED TO THIRD PARTIES WITHOUT WRITTEN CONSENT OF DIVERSIFIED WOODCRAFTS, INC. ANY REPRODUCTION IN PART OR WHOLE WITHOUT WRITTEN CONSENT IS SUBJECT TO LEGAL ACTION.



300 South Krueger Street  
Suring, WI 54174  
diversifiedwoodcrafts.com

TITLE:  
STEEL WORKBENCH  
ASSEMBLY INSTRUCTIONS

REV.	DESCRIPTION	DATE	NAME	ECN No.
A	CREATED DRAWING	11/28/16	EMK	N/A
REVISION LEVEL				

DRAWING NUMBER:	SCALE:	SHEET:	REVISION:
WB SERIES	NTS	11 OF 17	REV A

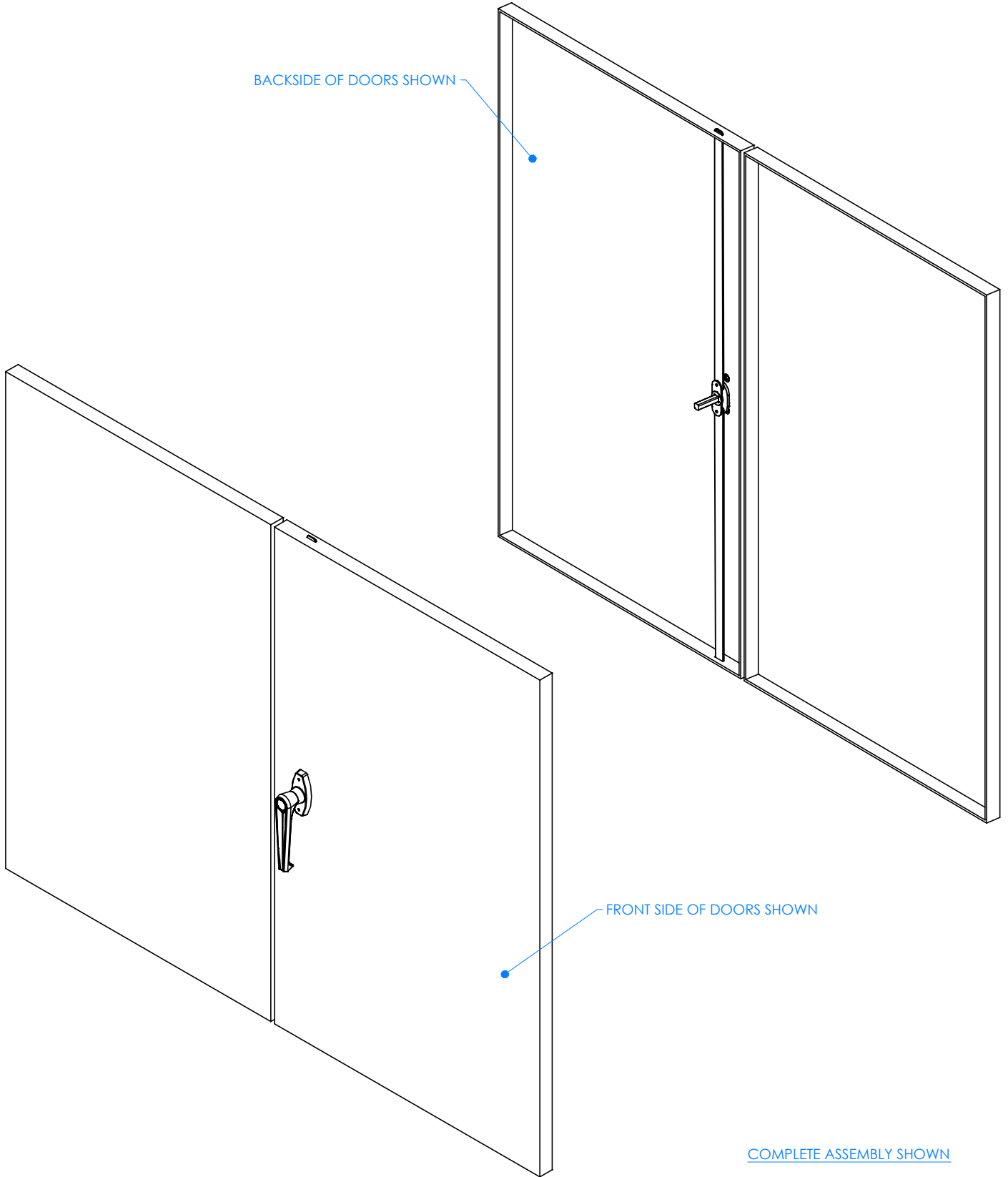

COMPLETE ASSEMBLY SHOWN

**NOTE:**

- 1. THESE ARE FOR THE TWO DOOR LOCKER BASE UNITS:
- 1.1. EX.: WB2, WB2BL, WBD2, AND WBD2BL.

ALL DIMENSIONS ARE IN INCHES UNLESS NOTED OTHERWISE		DWN BY: EMK	DATE DWN: 11/28/16
CABINET SQUARENESS = ± .0625		APR BY:	DATE APR:
FRACTIONAL VALUES = ± 1/32"		APR BY:	DATE APR:
- ALL VALUES ± OVERALL -			

CONFIDENTIAL:  
ALL DESIGN RIGHTS RESERVED  
THE INFORMATION, DATA, DESIGN, AND DRAWINGS EMBODIED IN THIS DOCUMENT AND ALL REPRODUCTIONS THEREOF ARE THE EXCLUSIVE PROPERTY OF DIVERSIFIED WOODCRAFTS, INC.

THESE DOCUMENTS ARE SUPPLIED WITH THE UNDERSTANDING THAT THEY WILL NOT BE DISCLOSED TO THIRD PARTIES WITHOUT WRITTEN CONSENT OF DIVERSIFIED WOODCRAFTS, INC. ANY REPRODUCTION IN PART OR WHOLE WITHOUT WRITTEN CONSENT IS SUBJECT TO LEGAL ACTION.



300 South Krueger Street  
Suring, WI 54174  
diversifiedwoodcrafts.com

TITLE:  
STEEL WORKBENCH  
ASSEMBLY INSTRUCTIONS

REV.	DESCRIPTION	DATE	EMK NAME	N/A ECN No.
A	CREATED DRAWING	11/28/16	EMK	N/A
REVISION LEVEL				

DRAWING NUMBER:	SCALE:	SHEET:	REVISION:
WB SERIES	NTS	12 OF 17	REV A

## Warning:

Misuse of vises can cause serious injury to eyes, hands and or other body parts. Vises must be set up and used properly. Before setup and use, read, understand and follow all instructions outlined.

ALWAYS make sure bench tops are properly secured.

Never use a hammer, extension pipe, or cheater bar on spindle handle of vise.

ALWAYS use proper mounting hardware in all mounting holes to hold vise securely.

NEVER unscrew movable jaw beyond maximum specified opening of vise.

ALWAYS inspect mounting hardware to ensure vise is securely fastened to work bench.

NEVER weld vise to any metal object.

ALWAYS inspect vise for stress fatigue or damage to the vise before using.

NEVER use a vise to press an object into or out of another object.

ALWAYS use vise of proper size and capacity to hold work object.

NEVER place pressurized containers or combustible materials in vise.

ALWAYS wear eye, face, and ear protection when using a vise.

NEVER wear loose clothing or jewelry while operating vise.

ALWAYS wear dust mask or respirator when working with wood, metal, chemical dusts or mists.

NEVER apply extreme heat or prolong heat to the vise as it may alter structural properties.

ALWAYS rest work piece against front jaw and guide rods.

NEVER tighten work piece at the edge (top or side) of the vise as this may break vise casting

ALWAYS wear restrictive hair covering and anti slip footwear while operating vise.

ALWAYS only hand tighten vise.

ALWAYS maintain the vise – grease main screw regularly.

## Mount Back Jaw Casting to Workbench

- Pre-drill holes for mounting screws using template provided. Be sure to drill holes straight and deep enough to accommodate the full length of the screw. Use recommended drill sizes only (see template provided).
- It is **CRITICAL** that the back jaw casting is mounted firmly and accurately to the workbench surface. **NO GAPS** between the casting and the workbench should be present. Use shims as needed. Refer to figure #1 below.
- **DO NOT** attach the vise to the end grain side of the workbench. By attaching the vise to the side grain side of the workbench the mounting screw will have a much stronger hold.
- When attaching the back jaw casting to the workbench, take care to ensure there is full contact of the casting to the workbench surface before tightening the mounting screws.
- The vertical portion of the back jaw against the front edge of the workbench and the horizontal portion of the casting on the underside of the bench must have full contact with the workbench. Use shims to eliminate any gaps that may be present.
- Any gaps between the casting and the workbench surface will cause flexing of the casting when tightened down, which could result in failure of the casting. Figure 1.
- **MOUNTING HARDWARE:** Use the #14 x 1-1/2" Counter-Sink Wood Screws (2) for the front edge mounting holes and the 5/16" x 2-1/2" Lag Screws (2) and the 5/16" Flat Washers (2) for underneath the workbench

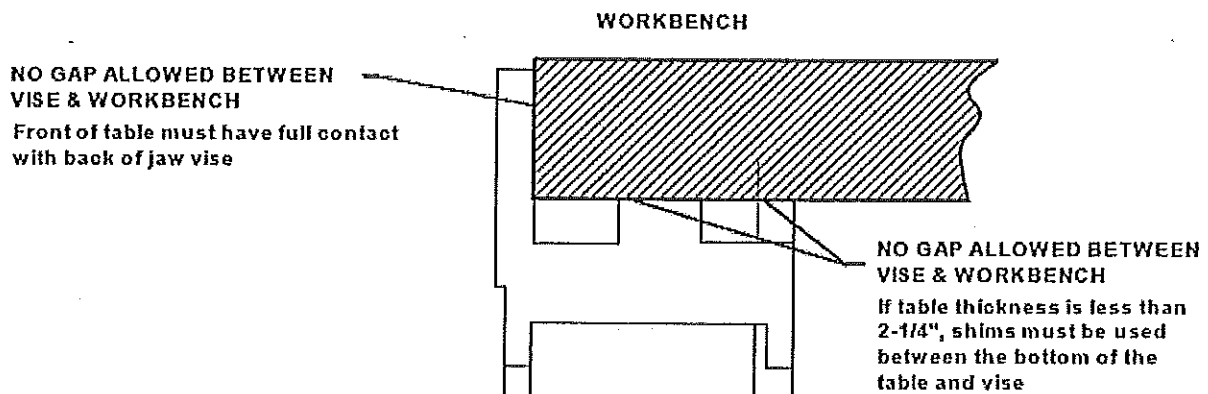
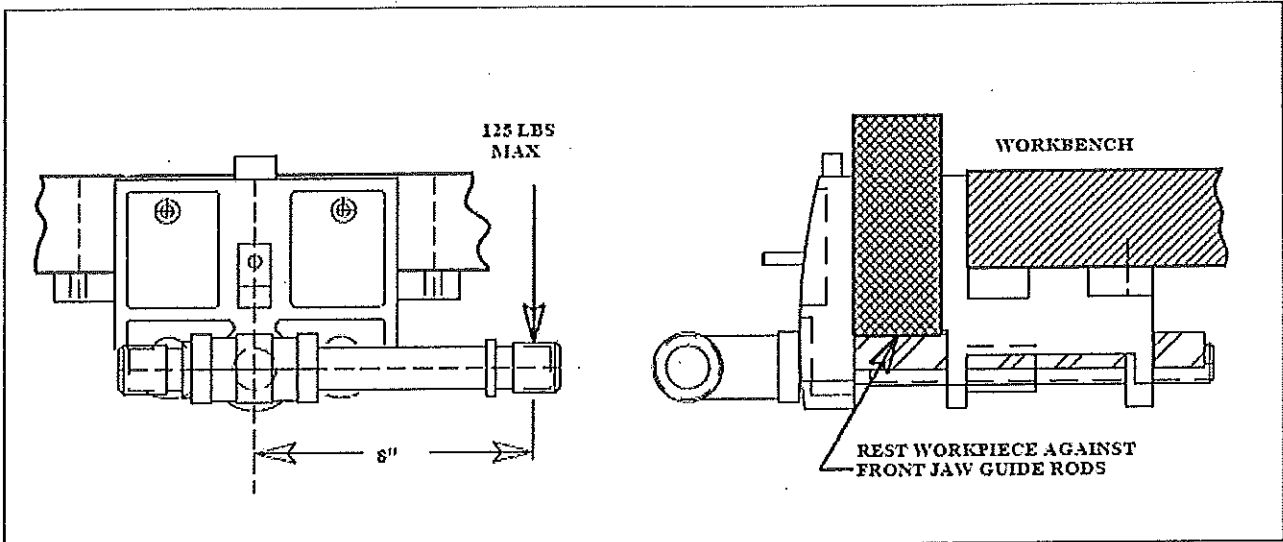
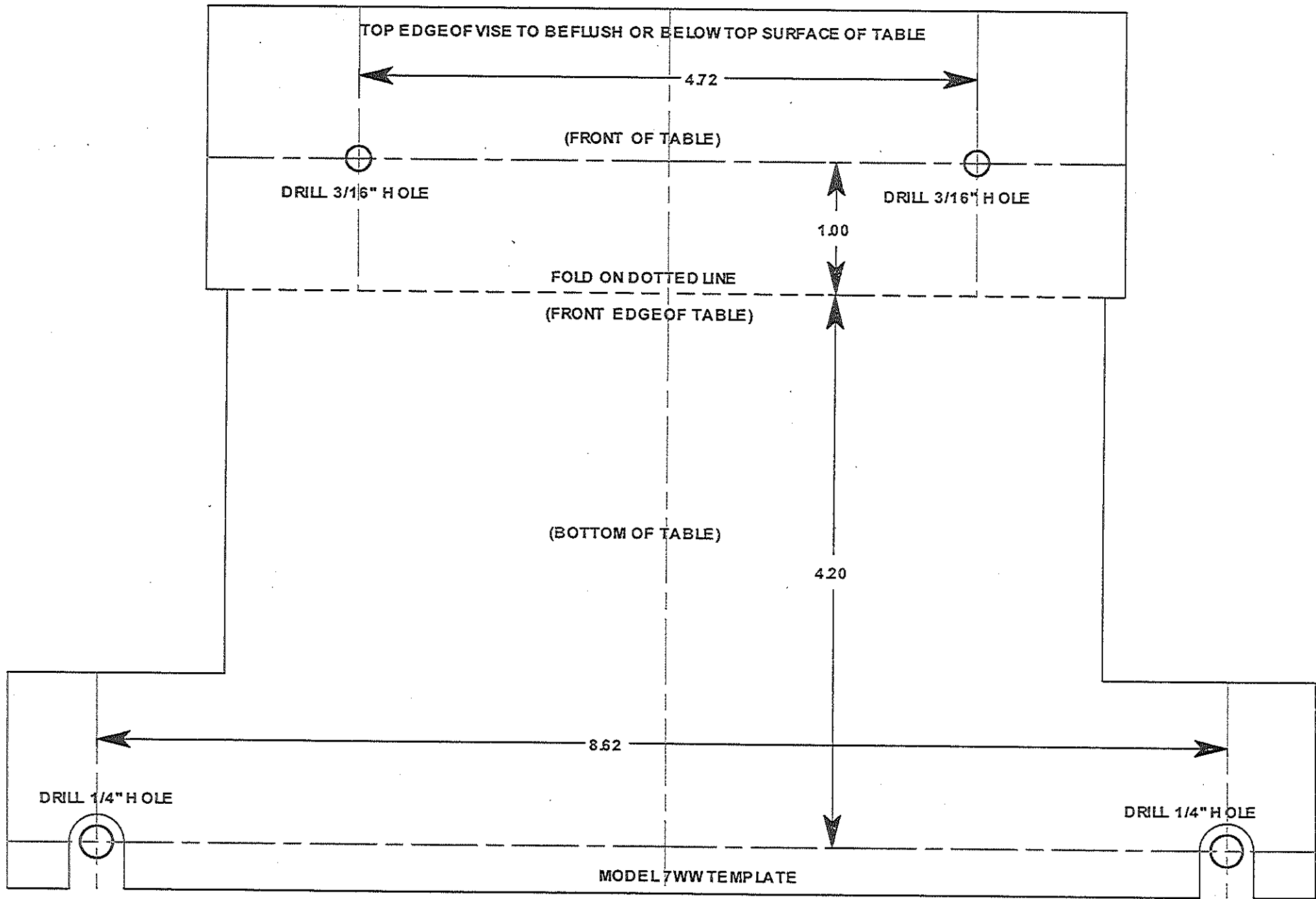

Figure 1: Mount Back Jaw Casting to Work Bench

## Caution:

Do not exceed the maximum applied torque of 1,000 inch-pounds (125 foot-pounds). Also, failure to rest work piece against the front jaw and the guide rods may also cause the castings to flex resulting in failure. See Figure 2.







# Butcher Block (Varnished Tops) *Maintenance & Repair*

## SPILLS

- Be sure any spills are cleaned up immediately. Excessive moisture and certain chemicals allowed to stand on a finished surface can cause damage.
- Clean spills or soiled areas with a damp cloth and dry thoroughly.
- Periodically, apply a coat of spray wax, paste wax, or lemon oil to finished surface. This will enhance and protect the finish and insure a moisture barrier is intact in the event the finish becomes scratched or worn.

## SCRATCHES & DENTS

- Minor scratches and dents can be easily repaired by rubbing the affected area with steel wool or fine grit (#220) sandpaper. Remember, when rubbing or sanding always sand with the grain of the wood. Feather edges of repair in to the surrounding area. Remove all dust and residue and apply a coat of clear lacquer type finish or paint. Clear lacquer type finish can be purchased at most paint or hardware stores. Small cans of touch-up paint are available from your dealer or representative. Paint colors can easily be matched at most paint stores. Confine touch-up only to the area that was sanded. Remember, follow manufacturing directions on product label when refinishing.
- Major scratches and gouges where large portions of wood have been removed or damaged should be handled by a professional experienced in furniture repair with the proper tools and equipment.

## MINERAL STREAKS

- Mineral Streaks—Natural Coloring of wood due to mineral deposits in the tree. Repair is not required and will add to the individuality of your table. Sizes can range up to a 1/4" wide and up to 3" in length.

## HUMIDITY GUIDELINES

Your Butcher Block was kiln-dried to an initial moisture content of 7.6%. In order to maintain the beauty and integrity of your Butcher Block, it is recommended that special care be taken to keep the relative humidity and temperature within your home or warehouse in the highlighted range. This will limit the amount of expansion and contraction in your natural wood product and minimize the risk of environmental damage.

- **Environment Acclimation:** Environmental damage does not constitute defective product. Allowing your Butcher Block to acclimate to the environment for at least 72 hours prior to installation, following recommended installation practices that allow your Butcher Block to move with the conditions and controlling the environment itself are all key factors that determine the life of your product.
- **Temperature Changes:** It is important to note that as winter temperatures drop, so does relative humidity in the air. The heaters come on which further dries the air. Keeping the area humidified to an acceptable level usually becomes necessary during the winter months. The opposite is true in spring and summer as humidity rises, dehumidifiers and air conditioners become the method of control.

		RELATIVE HUMIDITY %																	
		5	10	15	20	25	30	35	40	45	50	55	60	65	70	75	80	85	90
TEMPERATURE (°F)	30	1.4	2.6	3.7	4.6	5.5	6.3	7.1	7.8	8.7	9.5	10.4	11.3	12.4	13.5	14.9	17	18.5	21
	40	1.4	2.6	3.7	4.6	5.5	6.3	7.1	7.8	8.7	9.5	10.4	11.3	12.4	13.5	14.9	17	18.5	21
	50	1.4	2.6	3.6	4.6	5.5	6.3	7.1	7.9	8.7	9.5	10.3	11.2	12.3	13.4	14.8	16	18.4	20.9
	60	1.3	2.5	3.6	4.6	5.4	6.2	7	7.8	8.6	9.4	10.2	11.1	12.1	13.3	14.6	16	18.2	20.7
	70	1.3	2.5	3.5	4.5	5.4	6.2	6.9	7.7	8.5	9.2	10.1	11	12	13.1	14.4	16	17.9	20.5
	80	1.3	2.4	3.5	4.4	5.3	6.1	6.8	7.6	8.3	9.1	9.9	10.8	11.7	12.9	14.2	16	17.7	20.2
	90	1.2	2.3	3.4	4.3	5.1	5.9	6.7	7.4	8.1	8.9	9.7	10.5	11.85	12.6	13.9	15	17.3	19.8
	100	1.2	2.3	3.3	4.2	5	5.8	6.5	7.2	7.9	8.7	9.5	10.3	11.2	12.3	13.6	15	17	19.5

*Example: If conditions in a warehouse are 60% relative humidity at 50 degrees. Fahrenheit Dry wood will pick up moisture until 11.2% is reached, regardless of wood species and initial moisture content.*